

Curriculum Vitae

Karl Emilio Pircher

Education certificates:

2000 / Communication Mag. Of Arts
2000 / Certificate Degree
2000 / Diploma certificate
2000 / Price of Tyrol
1987 / Master Craftsman

Teaching experience:

2016-2017 / Semester 1 / Free University of Bozen-Bolzano / Master in Eco-Social Design. hores 184
2012-2013 / Semester 2 / University of Applied Arts Vienna, Prof. Greg Lynn Subject / Architecture Teatch. hores 40
2014-2015 / Semester 1 / University of Applied Arts Vienna, Prof. Oliver Kartak / 3D Design Teatch. hores 40
2014-2015 / Semester 2 / University of Applied Arts Vienna, Prof. Oliver Kartak / 3D Design Teatch. hores 40
2014-2015 / Semester 1 / Fachhochschule Nordwestschweiz FHNW I, Prof. Armin Blasbichler / Design Teatch. hores 24

Professional and research activity:

2000-2002 / Lomography AG New Flash solution / Patent Colorflash
2004-2005 / Walking-Chair GmbH. / new shoe system / Patent high and low Heel

Publications:

Book about walking chair design studio / YOU DO DESIGN YOU
ISBN 978-99300056-1

I'm in charge of all 3D designs shown in the book and co-responsible of the book conception

In museum collections represented:

1. MAK / ping meets pong
2. MAK / Supersampler camera
3. MAK / Abstract animal cart
4. MAK / outlet cover
5. MAK / Chair 2000
6. Imperial / Walking-Chair
7. Imperial / HTLT Chair
8. Museum der Dinge Berlin / pourer
9. Museum der Dinge Berlin / Recycling Tool
10. Cultural Heritage in South Tyrol / Ping Pong meets

Selection of participation in exhibitions:

2017 /

The Game/ Kunsthalle Eurocenter Lana/ 22.September 2017 - 14. Oktober 2017

2016-2017 /

Museum of Applied Arts Budapest / BIKEOLOGY / 15. Juni 2016 - 17. Jan 2017

2016 /

STATE-OF-DESIGN-BERLIN / SISTER BLISTER

2015 /

Marta Herford Museum Sister Blister Light Objects at Kiosk 24, & Sister Blister Workshop

2015 /

La Triennale di Milano Sister Blister Red Headed and Walking Chair

2011 /

LA BIENNALE DI VENEZIA - IL PADIGLIONE ITALIA NEL MONDO /

host: Italienisches Kulturinstitut / location: Vienna / products: See you in Italy, You May, Animal Farm /

contact: Fabrizio Iurlano / curated by Claudia Maria Walther

2011 /

AUSTRIA DAVAJ! / curation: Peter Noever / host: MAK / location: Schusev State Museum of Architecture, Moscow, Russia / products: Animal Farm, Piano Table, Sister Blister / contributing artists: Johanna Braun, Manfred Wakolbinger, Franz West, Erwin Wurm, Heidulf Gerngross, Franz Graf, Nilb Ar Güres, Carola Dertnig, Günther Domenig, Georg Driendl, Stefan Sagmeister, Tamuna Sirbiladze, Brigitte Kowanz, Zenita Komad, Helmut Lang, Otto Muehl, Walking Chair

2010 /

VIENNA ART WEEK 2010 / host & location: Wiener Secession / contact: Robert Punkenhofer, artistic director Vienna Art Week / product: You May

2010 /

2000-2010 DESIGN IN WIEN / host & location: Wien Museum am Karlsplatz / curation: Peter Stuber and Tulga Beyerle / product: Lomo Supersampler, Animal Farm, Walking-Chair, You May

2009 /

TENERIFE DESIGN FESTIVAL — SOLO EXHIBITION

2009 /

MAK / HAPPY LANDING — SOLO EXHIBITION

Curation: Ron Arad

2006 /

ARS ELECTRONICA / host: Ars Electronica Center / location: Main Deck - Brucknerhaus, Linz, Austria / contact: Gerfried Stocker and Team / products: You May

2007 /

INTERIOR LIFESTYLE CHINA - FAIR & LECTURE / host: Messe Frankfurt / Shanghai, China / contact & curation: Colette Naumann

2006 /

Aram Gallery / WALKING CHAIR — SOLO EXHIBITION / curation: Daniel Charny

2004 /

MAK Maknight Ping meets Pong

2003 /

A DESIGN NOW / host & location: Austrian Cultural Centre, New York, United States / contact: Christoph Thun-Hohenstein / PING Meets PONG, Be Occupied Chair

2003

I set up Walking-Chair Design Studio in Vienna, with Fidel Peugeot.

I am responsible for the 3D design and Fidel for 2D design.

Selection of the realized projects.

documented in the accompanying presentation:

Walking-Chair Design Gallery / Responsible for the co-curation

documented in the accompanying presentation:

Mother tongue: German ***

Second language: Italian **

Third language: English *

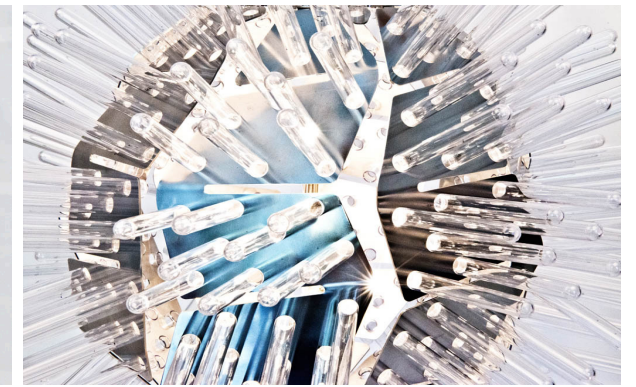
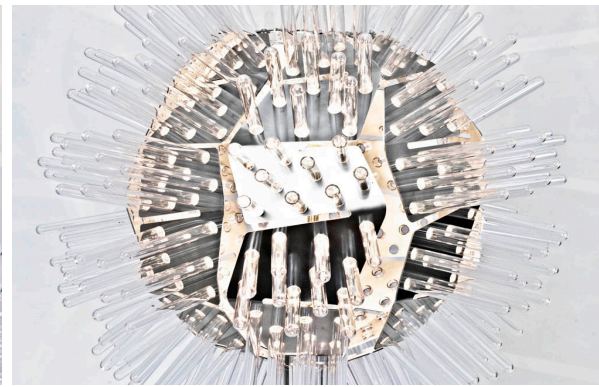
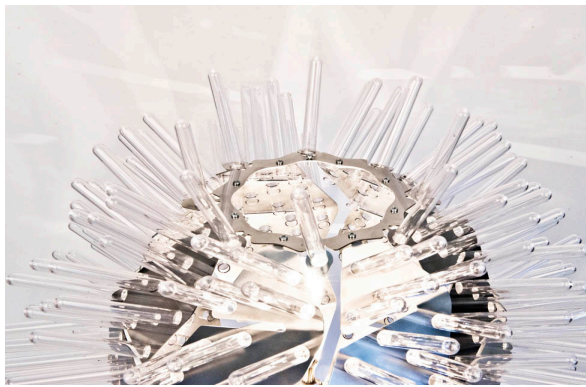
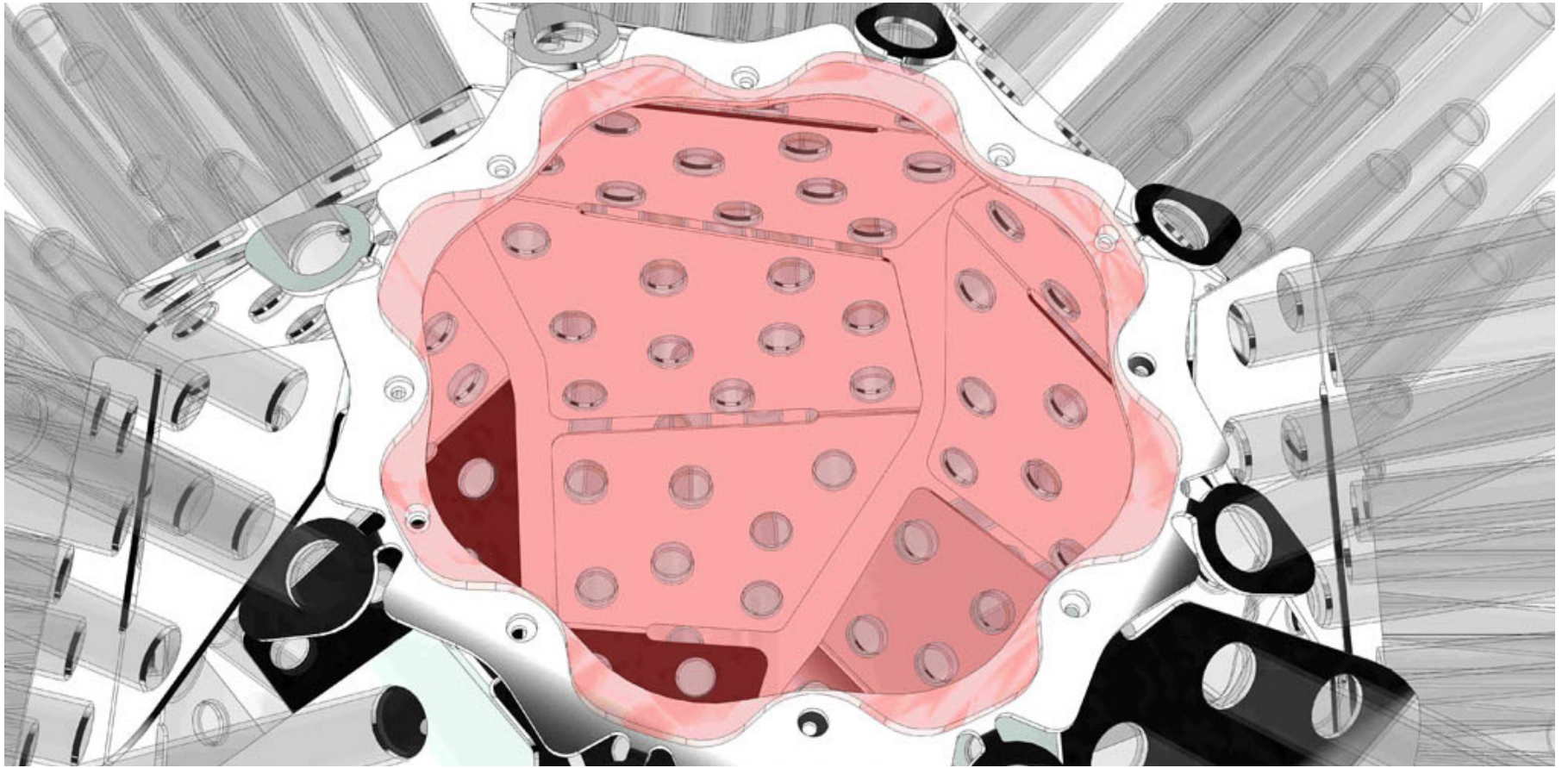

BIOTECH GRAINER / LIGHT INSTALLATION / 2017 — Made by the Artist



MINI POST FOR AUSTRIAN POST AG / 2017 — This is a further development of the Mini Post which we have developed for the Post AG in 2015. With the goal of implementing the contents in a smaller and cheaper object. The goal is to have one in every post office in Austria.



MARIEN APOTHEKE WIEN / SCAFFOLDING COVER /2017 — The scaffolding cover is sewn sustainably to bags in a migrant workshop.



MARIEN APOTHEKE WIEN / ARCHITECTURAL ART / 2017 — The historic facade was stocked with forged ginkgo leaves. This installation is permanent and had to be approved by the monuments office.



GARNITUR / 2016 — Garnitur a new sofa system for public and private residential areas made of solid larch wood and leather/fabric upholstery. The entire line of furniture consists of an armchair and different couches. Garnitur offers a various color designs. Both the pickled larch wood and the upholstery can be individually customized. — Exclusive manufacturer: Kohlmaier Wien



X — CHROMOSOME / 2015
DOG / 2015



READ — HED / 2015



MINI POST FOR AUSTRIAN POST AG / 2015 — The new children's playing corner for the upcoming Austrian Post AG branches is not a typical sale invite but embodies the character of the service provider as a transport and logistics specialist. The Minipost works as a cycle with the four stages: settle, send, catch and return. First the kids put the address, drawing or stamp on the packet, further settle it on the conveyer belt, send it by activating the belt, the color organ shows them the arrival of the parcel and they can return it. Due to the fact that parcels are the future of the service, those are available in different sizes but also typical post cards can be painted and then sent for free on the counter. A total of four children can play simultaneously – so pack up your kids and visit the Minipost at the sample branch in Wien Simmering.

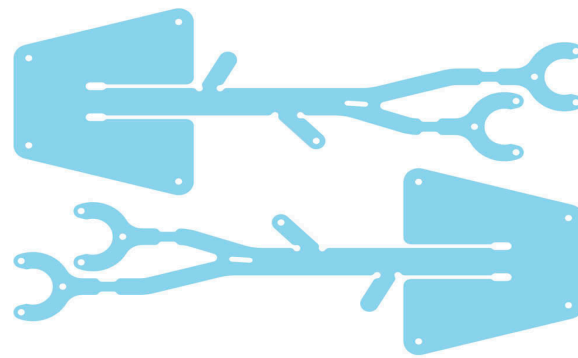

REBOTTLE TREE FOR VÖSLAUER / 2015 — PET bottle + RebottleTree for Vöslauer = a flower vase and a tool for the future. By bending up the flat metal plate, so transferring 2D into 3D not only restaurateurs but everyone can set used PET bottles, from size 0,33l to 1l, into scene and creating a hilarious tool for his/her table setting.

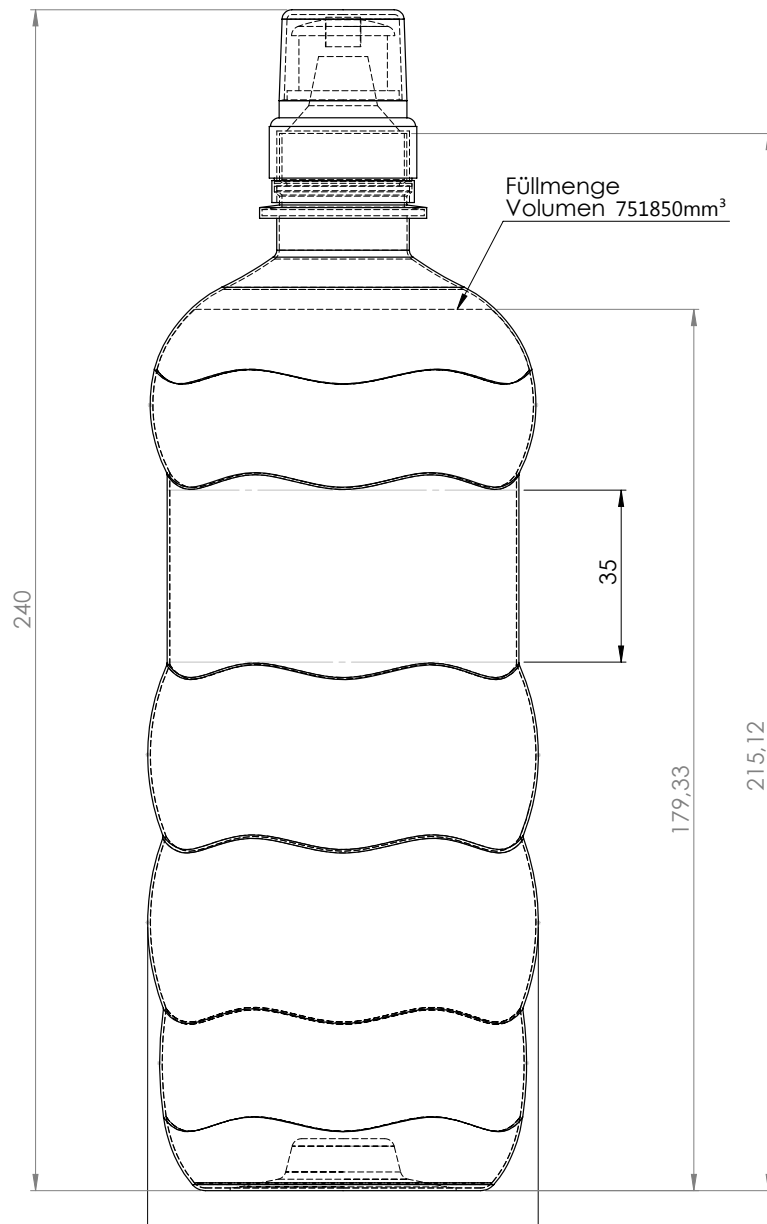

SPORT BOTTLE FOR VÖSLAUER / 2015 — The new sport Pet bottle for Vöslauer highlights not only the successful CI wave structure in a reinterpretation of a muscly six pack, but is also large-scaled in its dimensions. Furthermore through the developing and engineering process in our studio we were able to gain a good haptic grip which makes the new sport bottle the perfect companion for everyday's work (and chill) out.



JUNIOR BOTTLE FOR VÖSLAUER / 2015 — Fancy colours, a sport top, which can be opened and closed with one hand, a handy size and an improved haptic grip make it easier and more exciting for kids to drink regularly and for adults to animate them to a healthy drinking rhythm at an early stage.



GEWÜRZGARTEN / 2015 — The public green island in front of the Marien Apotheke Wien turned into a public herbes and spices garden maintained by the pharmacy. With regards to hygenical issues on the one hand and the wish to pick the herbs on a comfortable height for local residents at any age - we combined the plant pots with green metal poles. The forged ginko leaves are part of the Marien Apotheke's Corporate Identity and sparkle, glitter and twinkle spicy greets to the neighbourhood.

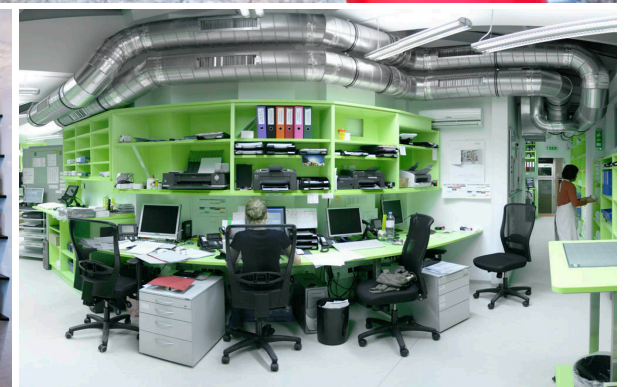

MARIEN APOTHEKE WIEN – THE SHOP / 2014 — Walking Chair Design Studio has been developing products for Marien Apotheke Vienna since 2003. Pharmacist Karin Simonitsch was the studio's first customer and has a distinct sense for innovative pieces. In 2014 the pharmacy has changed the complete interior design with a more customer based sales room for meeting and advising the clients. The room was intended to be colorful, warm and totally different from a casual cool, white looking for pharmacy. The ceiling is made with a Sister Blister light installation full of recycled empty, recycled, clean pharmaceutical tablet blister-packaging.



W*ORT / 2014 — Is a nonprofit creative writing centre in Lustenau, Austria, dedicated to the idea that children and young people are natural storytellers. Focusing on young writers aged 6 – 18, we use the resources in our community to foster their imagination and creativity and build confidence, self-respect and communicative skills.



WATER POURER H2Oho / 2013 — Is a pourer for using with all plastic bottles. It's handy, good looking, and very functional. Great to use for small and big hands alike, it turns your mineral waterbottle in to a lovely carafe. The H2Oho! is a collaboration with our longtime partner Voeslauer Mineral Water. Available in purple or torquoise.



MAXIMILIAN VON MEXIKO / 2013 — The exhibition „Maximilian of Mexico: The Dream of Imperial Rule“ at the Hofmobliendepot - Imperial Furniture Collection Vienna, documents the Life (1832-1867) of the brother of the Austrian Emperor Franz Joseph I. The exhibition presents the latest findings in research about the passionate collector and seafarer in a extensive selection of restored historic objects, paintings and utensils in his life.



DANCING TABLE / 2013 — A unique high tec table.



SISTER BLISTER / 2013 — Walking Chair has worked for Karin Simonitsch, a pharmacist and owner of Marien Apotheke Wien with a sense of creativity. The entrepreneur uses „Daisy“, a computer controlled packaging machine for pharmaceuticals. The colorful packaging leftovers (pill blisters) are collected by Walking Chair and turned into lamps. Each piece is unique, made by the artist. The following Sister Blister types are available: hanging lamps, floor lights, table lamps and wall lights.



WIENER ALPEN BENCH / 2013 — An outdoor bench and table furniture for the Vienna Alps.



The CeMM BRAIN LOUNGE / 2012 — CeMM stands for Research Center for Molecular Medicine of the Austrian Academy of Sciences) is the future lab of this research institute. Its purpose is to host interdisciplinary groups of scientists, artists and free thinkers to discuss and generate new strategies, ideas and notions. The new Brain Lounge has been created by Walking Chair in close cooperation with Director Giulio Superti-Furga.



SCHMATZ, MAMPE, SCHLÜRF / 2012 — Within the scope of the exhibition *Crunch, Munch, Slurp* at Zoom Children’s Museum the kids learn about food and its impact on health and the human body. In an interactive and playful way they explore food-related topics like hunger and health, the needs of nutrients our body, they find out what’s the link between food and movement, where food comes from, and what’s in our favorite foods, like spaghetti or French fries. They’ll put together a healthy lunch plate, steer the intestinal villi at our “body construction site”, can pedal, row, and step to see how many calories you burn, and they can have a look at fruit and vegetables through our “seasonal spectacles”. People in other countries have different food customs: what might a nomad child in Somalia, an Indian seamstress, a Scottish shepherd, or an astronaut eat?



APOLLINARIS BAR / 2012 — mobile bar system for the public indoor and outdoor space, Apollinaris/Coca Cola, Germany.



PUFF BAR / 2012 — In the end of 2012 Walking Chair was invited to conduct the first gastronomic project of two rookie gastronomes (Matthias Euler-Rolle and Thomas Polak), who finally wanted to fulfill their dream of having their own bar. The location – an old brothel – was to be redesigned without any big structural alterations.

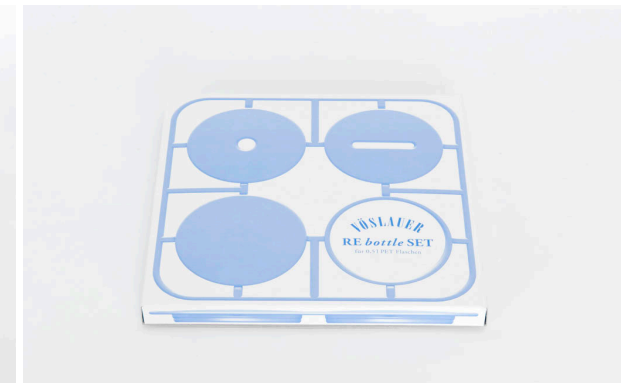
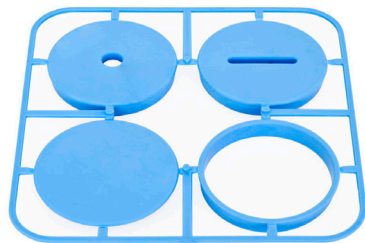

RE-BOTTLE SET /2011 — A mini container for your desk. Collect your empty plastic bottles, cut the bottle in the middle and create a vase, cash box and container. Originally developed for Vöslauer Mineral Waters.



APOLLINARIS BOTTLE COOLER / 2011 — A custom made bottle cooler for the international mineral water brand Apollinaris/Coca Cola, Germany.



APOLLINARIS DESIGN GLASS / 2011 — A custom made glass for the international mineral water brand Apollinaris/Coca Cola, Germany.



OTTAKRINGER BEER GLASS / 2011 — A custom made beer glass family for Ottakringer brewery



OTTAKRINGER BOTTLE OPENER / 2010 — For Ottakringer Brewery.

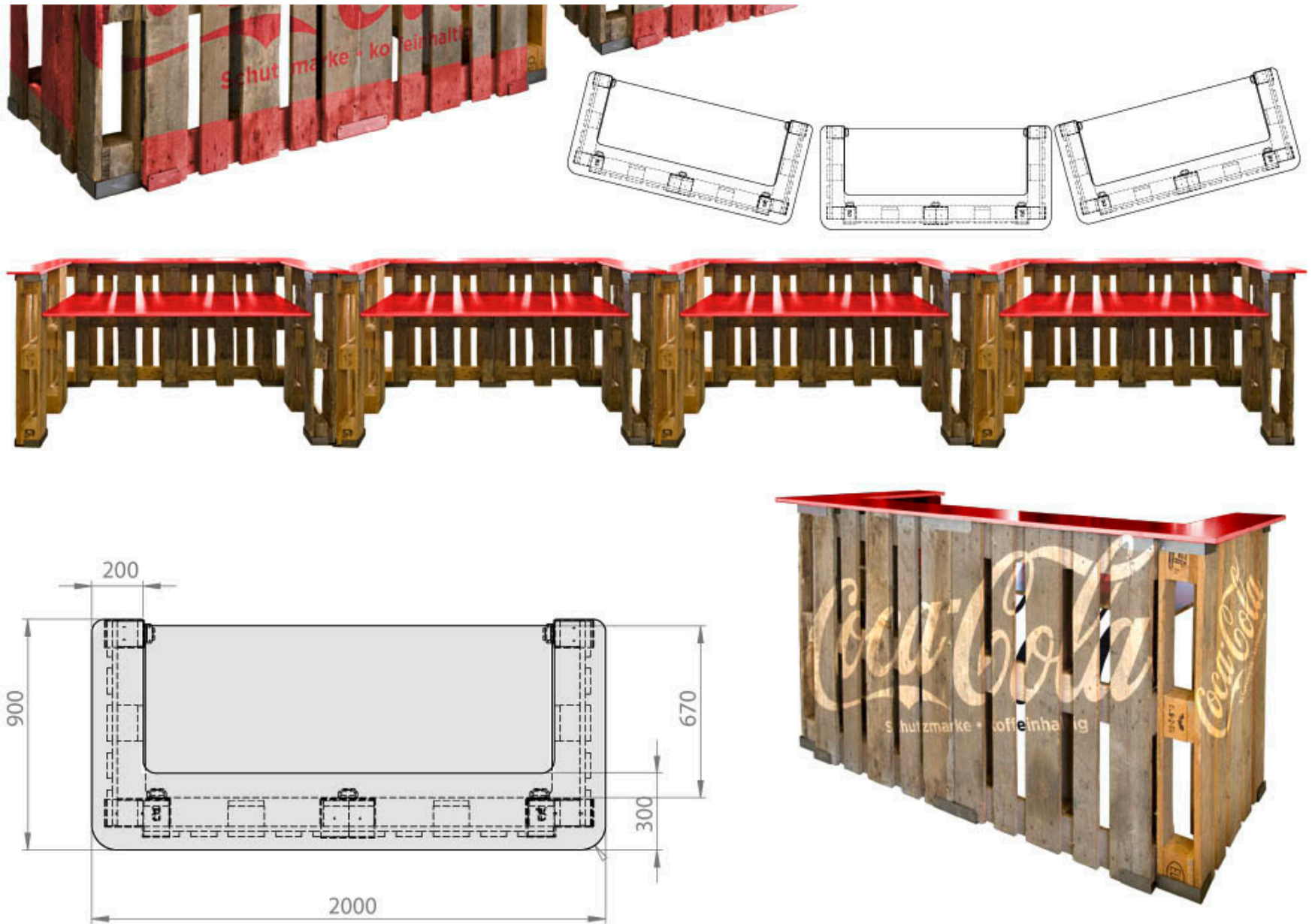

EU-PALLET BAR / 2010 — An austrian event agency successfully organizing catering- and barevents in the fashion industry has commissioned Walking Chair to design a simple bar based on simple materials. The bar consists of standardized EU pallets (80 x 120cm), and specially developed connection elements convert simple pallets into a fashionable bar. Main requirement was to develop a trendy bar with lowest cost and produced from reusable elements. Planning and production time was less than three weeks.



IKEA PHENOMENON / 2010 — Billy and Ivar – these infinitely extendable shelving systems have become a feature of almost every modern home. The furniture store from Sweden that addresses its customers informally and gives its furniture names has like no other changed the way of life and the home environment of the people of Europe in the last 50 years, introducing designs capable of being mass produced into our homes. The exhibition shows IKEA furniture designs from the 1950s to the present and examples of international and Scandinavian design that served IKEA as inspiration. Examples are also used to illustrate topics such as systems furniture, sustainability and the concept of the unmistakable brown cardboard flat pack.



GRAND PIANO TABLE / 2010 — An exclusive instrument and coffee house table for a small audience.
GUITAR BIRD / 2010 — Fidel's standing guitar. An unique instrument made by the artist.



YOU MAY / 2009 — YOU MAY is a new furniture for the urban public space. YOU MAY does many things: it is a bar and a bench, conference table and quiet corner at the same time, it functions as a lounge as well as a stage or workspace. YOU MAY works with innovative materials, different seat heights, it plays with niches and corners. It provides communication and privacy for up to 15 persons at the same spot. The furniture itself becomes a vivid meeting point, it invites to work, discuss, eat and relax.



ANIMAL FARM / 2008-2009 — My friend, the animal: A charming horde of unprecedented, yet friendly furniture! These unique furniture items have the shapes of abstract animals and are created of used furniture parts, packaging materials and instruments. As it is common with farm animals, these members of the Animal Farm serve a purpose and are useful for their owner, ...even if he recognizes it at the second glance.



SURFACE TABLE / 2007 — A unique table with an irregular surface. An art piece made by the artist.



PERSONAL SHOPPER / 2007 — The assignment was to curate a selection of products and objects from the entire exhibition, to later stage them for a presentation in a 100m² area. All objects of the See You presentation were hung on invisible string throughout a partly mirrored room. A table area was mounted to the prominent column in the room's center, on which presented objects were arranged. The goal was to create an atmosphere of unity between objects and visitors. With the mirror elements placed on the wall, dot patterns were created. With a closer look they disclose themselves as shapes of faces with ears. This project was the origin of Walking Chair's later produced mirror series called.

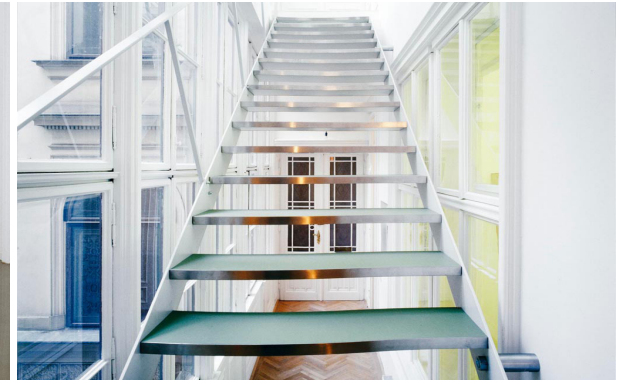

PLOIL, KREPP & BOESCH / 2007 — Walking Chair accomplished the redesign and enlargement of the law office „Ploil, Krepp & Boesch“ located in an impressive Vienna Ringstrasse palace. In a first phase the office was enlarged with a new level connected with internal stairs. The office’s large art collection – also including art designs from Walking Chair – was integrated into the new interior design. The overall construction perfectly mirrors the elegance and fragility of the famous Ringstrassen architecture.

SCHIEFE LAMPE / 2006 — A dimmable light object for offices, without any 90° angles, schiefe means aslope.



AQUANA — FORMULA AQUA / 2004-2007 — Architecture waterpark for the municipality of Banja Luka, Bosnia-Herzegovina. Aquana based on the concept of a motor racing track formula aqua was designed to be a through-flowing swim circuit, the whole park area covers more than 40.000 square metres. landscape architecture, terraced relaxation area with view over the Formula Aqua water race track. Handcrafted stainless steel facade — Formula Aqua main building inspired by the water's surface, made by craftsmen from Banja Luka.



PET LIGHT #33 / 2006 — An hanging lamp and light structure created from 33 bottles, twinkling like stars, creates beautiful reflections that are very depending on the shape, contents and colour of the bottles.



MONTE BELLO / 2006 — This mountain-lounge and modular sofa-system is suitable both for public and private interior zones. Monte Bello has been developed for the exhibition a_schau (Austrian architecture in the 20th & 21st century) in the Vienna Architecture Center 2005 and is under production by Kohlmaier Wien

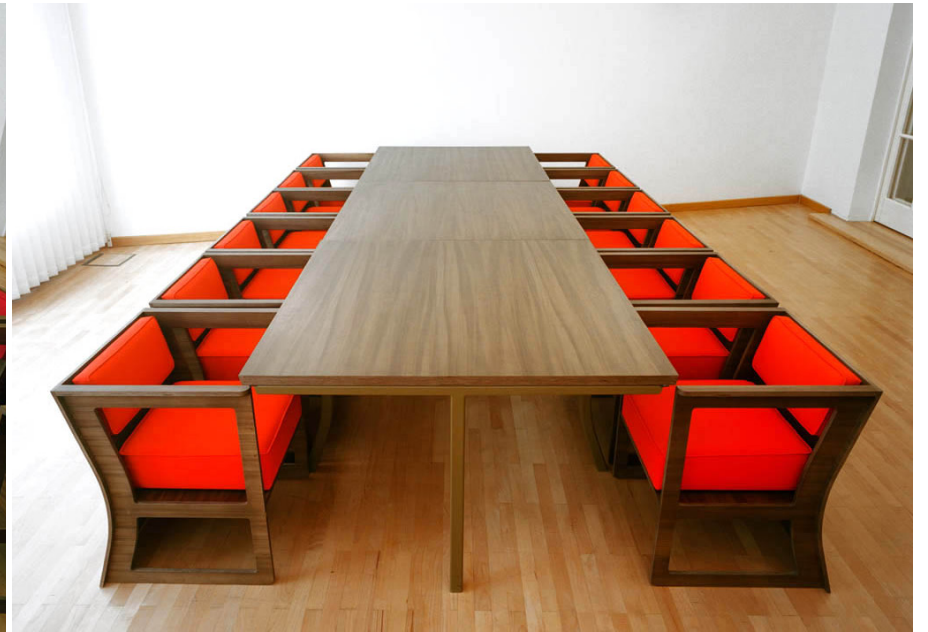

DENKSTATT FURNITURE / 2006 — Meeting and conference table with different functions.



MY FIRST CHANDELIER / 2004 — The world's smallest, smartest and sweetest chandelier gets even smaller with only 7 handcut Austrian crystals, even smarter adapting to the ground-breaking LED technology using a 3W bulb/270 Lumen or a 6W bulb/470 Lumen and even sweeter because it saves a lot of energy while letting you dip into the same atmosphere.



PING MEETS PONG / 2002 — You say Ping and we say Pong. Our „Ping Meets Pong“ table was developed as one of the first Walking Chair furniture designs in 2002. It can be used as dining/conference table with a turntable (so-called lazy susan) and can be easily converted to a ping pong table by just adding an easily fixable plug-on net. For your success, please follow these golden rules.



COLORSPASH CAMERA / 2003 — Developed for Lomography. revolving flash system worldwide patent.
Immerse yourself in a whirlpool of intense colors with the Colorsplash Camera! The built-in colorflash system of this 35mm point and shoot snapper allows you to paint your photos in any color that you like. Try it with a slide film and get ultra-colorful snapshots.



FOTO CLIPS / 2002 — Fotoclips introduces two new dimensions to photography. Every bag contains clear 2D and orange 3D Fotoclips, empowering you to create unlimited constructions of your own beautiful fotos. For Lomography.



WALKING CHAIR / 2000 — Walking Chair — A chair that walks. Didn't we always dream that the domestic ambience we live in responds to our momentary needs – with pieces of furniture moving on their own? A mixture between a servant and a pet the Walking Chair follows wherever we go, but of course, over time it might learn and find its own way. One day, we may come home and be alone. Remember: Before chairs started to walk, men have been walking on the moon.

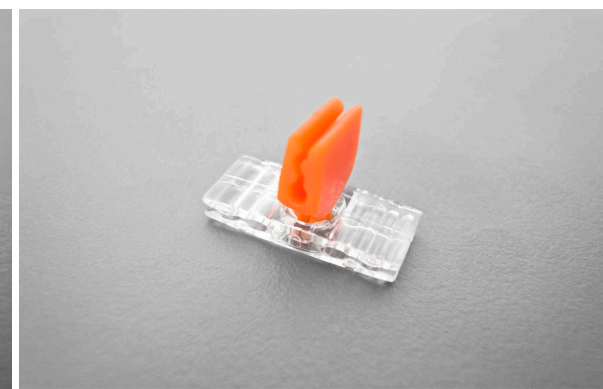
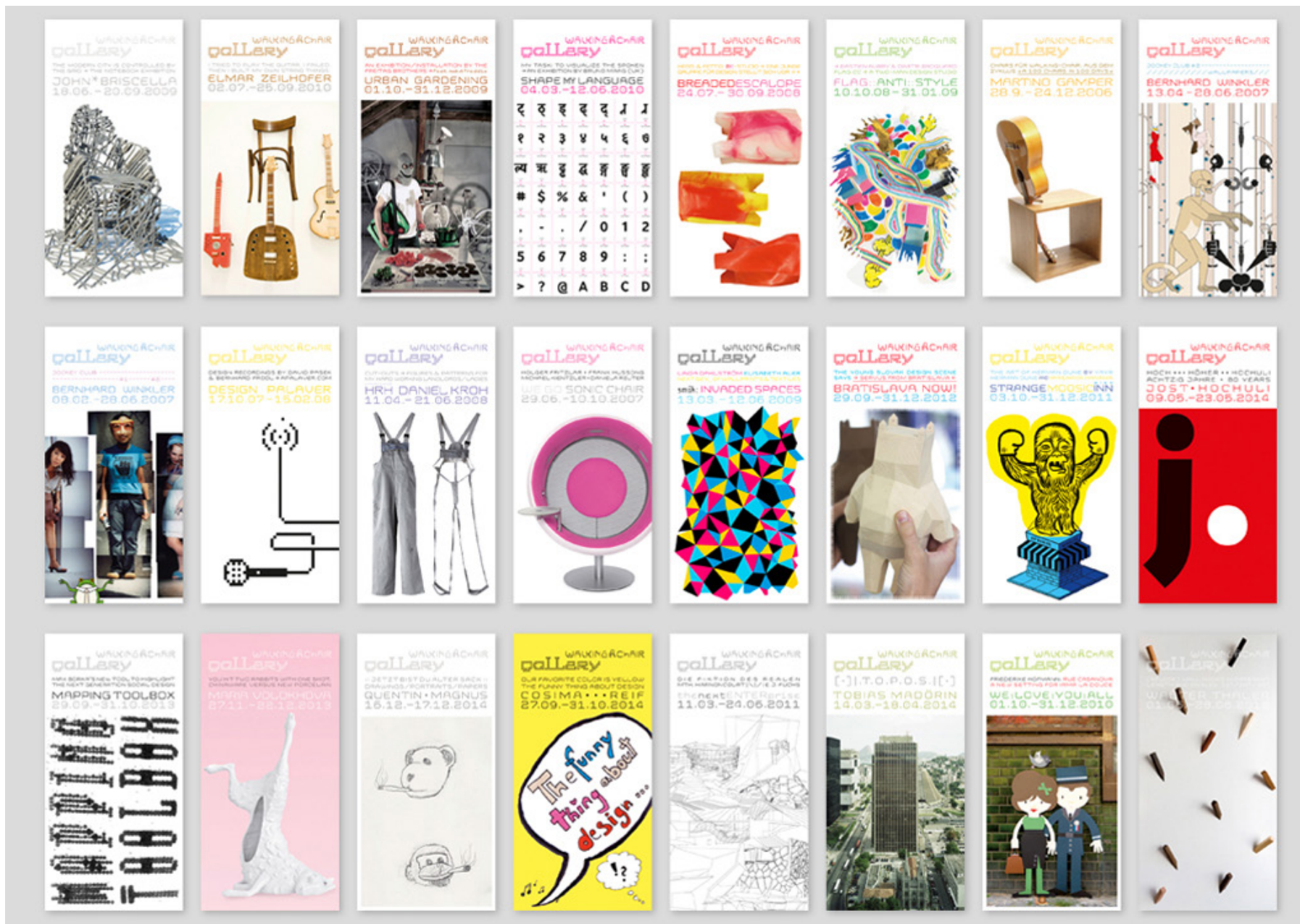

WALKING-CHAIR - GALLERY / 2006-2016 — Exhibitions Overview